

VC10-4TC 电偶式温度输入模块用户手册

注意:

在开始使用之前, 请仔细阅读操作指示、注意事项, 以减少意外的发生。负责产品安装、操作的人员必须经严格培训, 遵守相关行业的安全规范, 严格遵守本手册提供的相关设备注意事项和特殊安全指示, 按正确的操作方法进行设备的各项操作。

1 接口描述

1.1 接口说明

VC10-4TC 的扩展电缆接口和用户端子均有盖板, 外观如图 1-1 所示。打开各盖板后便露出扩展电缆接口和用户端子, 如图 1-2 所示。



图 1-1 模块接口外观图

图 1-2 模块接口端子图

VC10-4TC 通过扩展电缆接入系统, 扩展电缆接口用于系统其他扩展模块的连接, 具体方法参见

1.2 接入系统。

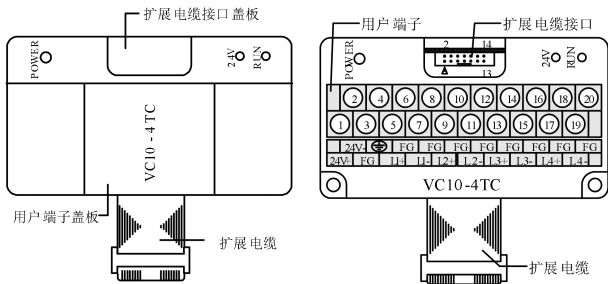
VC10-4TC 用户端子的定义见表 1-1。

表 1-1 用户端子定义表

序号	标注	说明	序号	标注	说明
1	24V+	模拟电源 24V 正极	11	L2-	第 2 通道热电偶信号负极输入端
2	24V-	模拟电源 24V 负极	12	FG	屏蔽地
3	•	空脚	13	L3+	第 3 通道热电偶信号正极输入端
4	⊕	接地端	14	FG	屏蔽地
5	L1+	第 1 通道热电偶信号正极输入端	15	L3-	第 3 通道热电偶信号负极输入端
6	FG	屏蔽地	16	FG	屏蔽地
7	L1-	第 1 通道热电偶信号负极输入端	17	L4+	第 4 通道热电偶信号正极输入端
8	FG	屏蔽地	18	FG	屏蔽地
9	L2+	第 2 通道热电偶信号正极输入端	19	L4-	第 4 通道热电偶信号负极输入端
10	FG	屏蔽地	20	FG	屏蔽地

1.2 接入系统

通过扩展电缆, 可将 VC10-4TC 与 VC10 系列 PLC 主模块或其他扩展模块连接在一起。其扩展电缆接口也可用于连接 VC10 系列的其他相同型号或不同型号的扩展模块。如图 1-3 所示。



图 1-3 与主模块和其他扩展模块的连接示意图

1.3 布线说明

用户端子布线要求, 如图 1-4 所示。

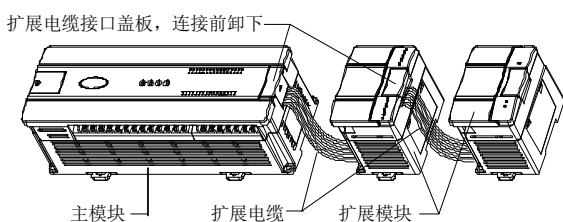

图 1-4 用户端子布线示意图

图中的①~⑤表示布线时必须注意的 5 个方面:

1. 热电偶信号建议通过屏蔽补偿电缆接入。电缆应远离电源线或其他可能产生电气干扰的电线。使用长的补偿电缆容易受到噪声的干扰, 建议使用长度小于 100m 的补偿电缆。补偿电缆存在阻抗, 会引入测量误差, 特性调整可解决这个问题, 具体操作参见 3 特性设置。
2. 如果存在过多的电气干扰, 连接屏蔽地 FG 到模块接地端 PG。
3. 将模块的接地端 PG 良好接地。
4. 模拟供电电源可以使用主模块输出的 24Vdc 电源, 也可以使用其它满足要求的电源。
5. 将不使用通道的正负端子短接, 以防止在这个通道上检测出错误数据。

2 使用说明

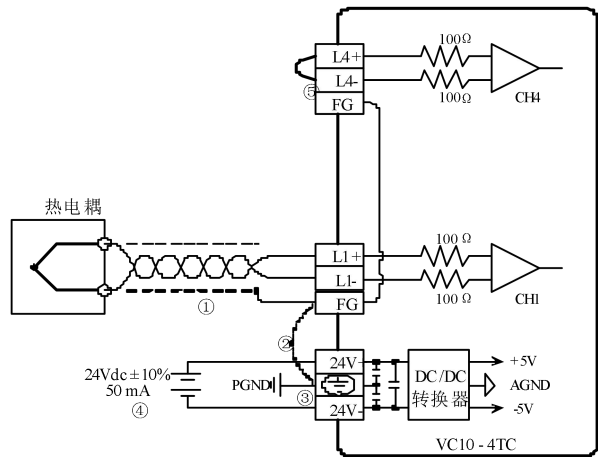
2.1 电源指标

表 2-1 电源指标

项目	说明
模拟电路	24Vdc (-15%~+20%), 最大允许纹波电压 5%, 50mA (来自主模块或外部电源)
数字电路	5Vdc、72mA (来自主模块)

2.2 性能指标

表 2-2 性能指标

项目	指标			
	摄氏(°C)		华氏(°F)	
输入信号	热电偶: 类型 K、J、E、N、T、R、S (每个通道 7 种都可使用), 共 4 通道			
转换速度	(240±2%) ms × 4 通道 (不使用的通道不转换)			
额定温度范围	类型 K	-100°C~+1200°C	类型 K	-148°F~+2192°F
	类型 J	-100°C~+1000°C	类型 J	-148°F~+1832°F
	类型 E	-100°C~+1000°C	类型 E	-148°F~+1832°F
	类型 N	-100°C~+1200°C	类型 N	-148°F~+2192°F
	类型 T	-200°C~+400°C	类型 T	-328°F~+752°F
	类型 R	0°C~1600°C	类型 R	32°F~2912°F
	类型 S	0°C~1600°C	类型 S	32°F~2912°F
数字输出	12 位 AD 转换, 以 16 位二进制补码存储			
	类型 K	-1000~+12000	类型 K	-1480~+21920
	类型 J	-1000~+10000	类型 J	-1480~+18320
	类型 E	-1000~+10000	类型 E	-1480~+18320
	类型 N	-1000~+12000	类型 N	-1480~+21920
	类型 T	-2000~+4000	类型 T	-3280~+7520
	类型 R	0~16000	类型 R	320~29120
类型 S	0~16000	类型 S	320~29120	

项目	指标			
	摄氏(°C)		华氏(°F)	
最低分辨率	类型 K	0.3°C	类型 K	0.54°F
	类型 J	0.2°C	类型 J	0.36°F
	类型 E	0.3°C	类型 E	0.54°F
最低分辨率	类型 N	0.3°C	类型 N	0.54°F
	类型 T	0.2°C	类型 T	0.36°F
	类型 R	0.5°C	类型 R	0.9°F
	类型 S	0.5°C	类型 S	0.9°F
精度	± (满量程的 0.5%+1°C), 纯水凝固点: 0°C/32°F			
隔离	模拟电路和数字电路之间用光电耦合器进行隔离。模拟电路与模块输入 24Vdc 电源内部隔离。模拟通道之间不隔离			

2.3 缓冲区

VC10-4TC 与主模块之间通过通讯缓冲区 (BFM) 交换信息。用户设置好后台软件界面后, 主模块会自动将信息写入 VC10-4TC 的缓冲区, 由此对 VC10-4TC 的状态进行设置。主模块会自动将 VC10-4TC 上报的信息显示在后台软件界面上, 见图 4-1~图 4-8。

VC10-4TC 的缓冲区具体内容见表 2-3。

表 2-3 缓冲区内容

BFM	内容	缺省值	读写属性
#100	CH1 通道平均值		R
#101	CH2 通道平均值		R
#102	CH3 通道平均值		R
#103	CH4 通道平均值		R
#200	CH1 通道当前值		R
#201	CH2 通道当前值		R
#202	CH3 通道当前值		R
#203	CH4 通道当前值		R
#300	模块故障状态字 0		R
#301	模块故障状态字 1		R
#600	通道模式字	0x0000	RW
#700	CH1 平均值点数	8	RW
#701	CH2 平均值点数	8	RW
#702	CH3 平均值点数	8	RW
#703	CH4 平均值点数	8	RW
#900	CH1-D0	0 (输入模式 0)	RW
#901	CH1-A0	0 (输入模式 0)	RW
#902	CH1-D1	12000 (输入模式 0)	RW
#903	CH1-A1	12000 (输入模式 0)	RW
#904	CH2-D0	0 (输入模式 0)	RW
#905	CH2-A0	0 (输入模式 0)	RW
#906	CH2-D1	12000 (输入模式 0)	RW
#907	CH2-A1	12000 (输入模式 0)	RW
#908	CH3-D0	0 (输入模式 0)	RW
#909	CH3-A0	0 (输入模式 0)	RW
#910	CH3-D1	12000 (输入模式 0)	RW
#911	CH3-A1	12000 (输入模式 0)	RW
#912	CH4-D0	0 (输入模式 0)	RW
#913	CH4-A0	0 (输入模式 0)	RW
#914	CH4-D1	12000 (输入模式 0)	RW
#915	CH4-A1	12000 (输入模式 0)	RW
#3000	冷端温度值 (调调用)		R
#4094	模块软件版本信息	0x1000	R
#4095	模块的识别码	0x4041	R

说明:

1. CH1 表示第 1 通道, CH2 表示第 2 通道, CH3 表示第 3 通道, CH4 表示第 4 通道。

2. 读写属性意义: R 表示只读属性, 向只读单元进行写操作无效。RW 表示可读可写属性。若读取不存在的单元, 将会获得 0 值。

3. BFM#200~BFM#203 用来保存输入数据的当前值。这个数值以 0.1°C 或 0.1°F 为单位(取决于 BFM#600), 平均数据存储在 BFM#100~BFM#103。

4. BFM#300 的故障状态信息见表 2-4。

表 2-4 BFM#300 的状态信息

BFM#300 位状态	开 (1)	关 (0)
b0: 错误	b1、b2 中任何一个为 1, 所有通道 AD 转换停止	无错误
b2: 电源故障	24Vdc 电源故障	电源正常
b3: 硬件故障	AD 转换器或其它硬件故障	硬件正常
b10: 数字范围错误	AD 转换数字输出值小于 -2048 或大于 2047	数字输出值正常
b12~b15: 保留		

5. BFM#301 的故障状态信息见表 2-5。

表 2-5 BFM#301 的状态信息

通道	位	开 (1)	关 (0)
1	b0	第 1 通道温度低于下限	第 1 通道正常
	b1	第 1 通道温度高于上限	第 1 通道正常
2	b2	第 2 通道温度低于下限	第 2 通道正常
	b3	第 2 通道温度高于上限	第 2 通道正常
3	b4	第 3 通道温度低于下限	第 3 通道正常
	b5	第 3 通道温度高于上限	第 3 通道正常
4	b6	第 4 通道温度低于下限	第 4 通道正常
	b7	第 4 通道温度高于上限	第 4 通道正常
保留	b8~b15		

6. BFM#600: 模式设定单元。用于设定第 1 通道到第 4 通道的工作模式。具体对应关系如图 2-1 所示。



图 2-1 模式设定单元与通道对应关系

字符值所表示的信息如表 2-6 所示。每个通道的转换时间为 240ms, 当有通道设置为关闭时, 对应的通道不执行 A/D 转换, 总的转换时间将减少。

表 2-6 数值与模式对应关系

序号	×值 (十六进制)	意义
1	0	K 型热电偶, 数字量单位为 0.1°C
2	1	K 型热电偶, 数字量单位为 0.1°F
3	2	J 型热电偶, 数字量单位为 0.1°C
4	3	J 型热电偶, 数字量单位为 0.1°F
5	4	E 型热电偶, 数字量单位为 0.1°C
6	5	E 型热电偶, 数字量单位为 0.1°F
7	6	N 型热电偶, 数字量单位为 0.1°C
8	7	N 型热电偶, 数字量单位为 0.1°F
9	8	T 型热电偶, 数字量单位为 0.1°C
10	9	T 型热电偶, 数字量单位为 0.1°F
11	A	R 型热电偶, 数字量单位为 0.1°C
12	B	R 型热电偶, 数字量单位为 0.1°F
13	C	S 型热电偶, 数字量单位为 0.1°C
14	D	S 型热电偶, 数字量单位为 0.1°F
15	E	通道关闭
16	F	通道关闭

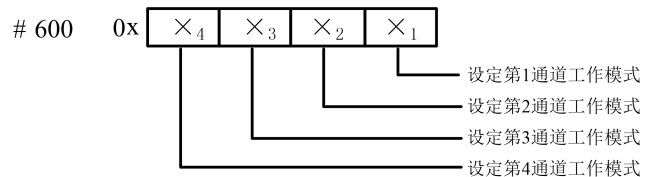
7. BFM#700~BFM#703: 平均采样次数设定。范围: 1~256。若输入的数超出了此范围, 将使用缺省值 8。

8. BFM#900~BFM#915 为通道特性设置数据缓存器，使用两点法设置通道特性，D0、D1 表示通道输出的数字量，D0、D1 数据的单位是 0.1℃，A0、A1 表示通道实际输入温度值，A0、A1 数据的单位是 0.1℃，每通道占用 4 个字。若更改通道的 D0、D1 数值，即可更改通道特性，D0、D1 允许在出厂设定基础上调整±1000 (0.1℃)，即 D0 允许调整的范围为-1000~+1000 (0.1℃)，D1 允许调整的范围为 11000~13000 (0.1℃)，若设定值超出此范围，VC10-4TC 不会接收，并保持原有有效设置。

请注意：特性参数中均以 0.1℃ 为数据单位，对于华氏度 (°F) 参数，请按下述表表达式进行转换后再写入特性设置中：摄氏℃ = 5/9 × (华氏°F - 32)

9. BFM#4094：模块软件版本信息单元。自动显示在后台软件的 VC10-4TC 配置界面中的**模块版本**栏，见图 4-1。

10. BFM#4095 为模块识别码。VC10-4TC 的识别码是 0x4041。可编程控制器中的用户程序可以在程序中使用这个号码，以在传输和接收数据之前确认此扩展模块。

3 特性设置

VC10-4TC 的输入通道特性为通道模拟输入温度 A 与通道数字输出 D 之间的线性关系，可由用户设置，每个通道可以理解如图 3-1 中所示的模型，由于其为线性特性，因此只要确定两点 P0 (A0, D0)、P1 (A1, D1)，即可确定通道的特性，其中，D0 表示模拟量输入为 A0 时通道输出数字量，D1 表示模拟量输入为 A1 时通道输出数字量。



图 3-1 VC10-4TC 的通道特性示意图

设置通道特性的目的是为了调整模块的现场线性误差，由于模块的使用的环境温度的不同及使用补偿电缆的原因，会给 VC10-4TC 的测量结果带来误差，用户可以通过设定通道特性来消除此类误差。

考虑到用户使用的简便性，且不影响功能的实现，将 A0、A1 的值固定为当前模式下，模拟量的 0 点和 12000 (单位是 0.1℃)，也就是说图 3-1 中 A0 为 0，A1 为当前模式下的温度值的 12000 (单位是 0.1℃)，用户对此两项设置的写入无效。若不更改各通道的 D0、D1 值，仅设置通道的模式，那么，0 模式对应的特性如图 3-2 所示。

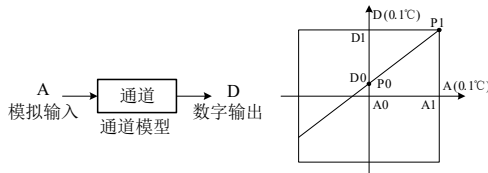

图 3-2 不更改各通道的 D0、D1 值，0 模式对应通道特性

需要注意的是，当模式设置为 1、3、时，即输出以华氏度 (0.1°F) 为单位时，在输出数据区相应单元将读出以 0.1°F 为单位温度值，但在通道特性设置区中的数据仍然以摄氏度 (0.1℃) 为单位，也就是说在通道特性设置区中的数据只能以摄氏度 (0.1℃) 为单位，在下面更改 D0、D1 数值时要注意这一点。

若更改通道的 D0、D1 数值，即可更改通道特性。D0、D1 允许在出厂设定基础上调整±1000 (0.1℃)，即 D0 允许调整的范围为-1000~1000 (0.1℃)，D1 允许调整的范围为 11000~13000 (0.1℃)。若设定值超出此范围，VC10-4TC 不会接收，并保持原有有效设置，图 3-3 实例表示了，若实际使用时 VC10-4TC 测量值偏高 5℃ (41°F) 时，K 型和 J 型热电偶的特性调整方法，请参考。

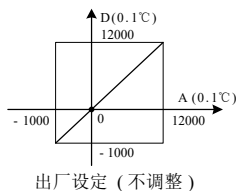

图 3-3 特性更改举例

4 应用示例

4.1 基本应用

例：VC10-4TC 模块使用其第 1 通道接入 K 型热电偶输出摄氏度温度，第 2 通道接入 J 型热电偶输出摄氏度温度，第 3 通道接入 K 型热电偶输出华氏度温度，关闭第 4 通道，前 3 个通道的平均值点数都设为 4，并且用数据寄存器 D1、D2、D3 接收平均值转换结果。

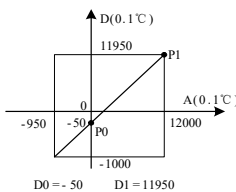
输出第 1 通道设置界面如图 4-1，设置完成后，点向下的黑色按钮，继续设置输出第 2 通道、3 和 4，设置界面分别如图 4-2~图 4-4。进一步详细说明参见《VC20/VC10 系列可编程控制器编程参考手册》。



图 4-1 模块第 1 通道设置界面



图 4-2 模块第 2 通道设置界面

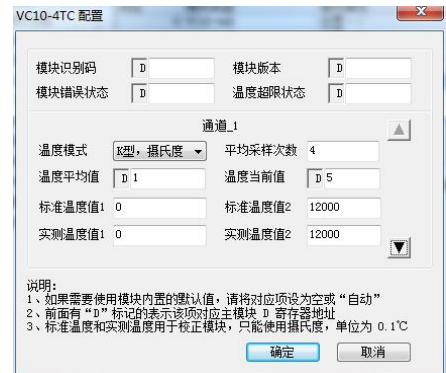

图 4-3 模块第 3 通道设置界面

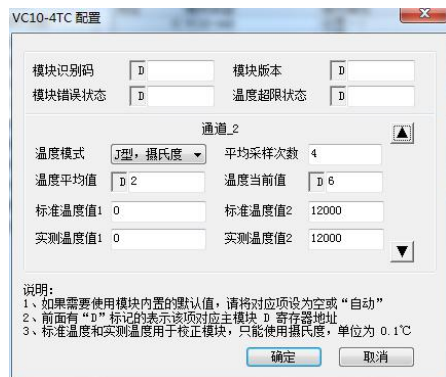

图 4-4 模块第 4 通道设置界面

4.2 特性更改

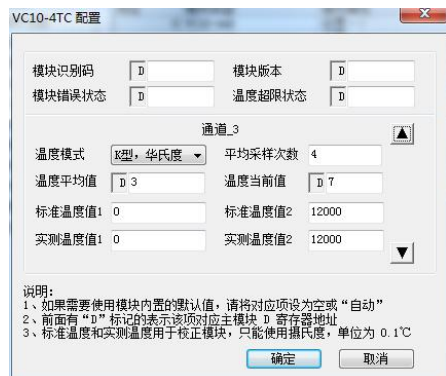
例：VC10-4TC 模块使用其第 1 通道接入 K 型热电偶输出摄氏度温度；第 2 通道接入 J 型热电偶输出华氏度温度；关闭第 3、4 通道。第 1、2 通道实现图 3-3 中特性；平均值点数都设为 4，并且用数据寄存器 D1、D2 接收平均值转换结果。

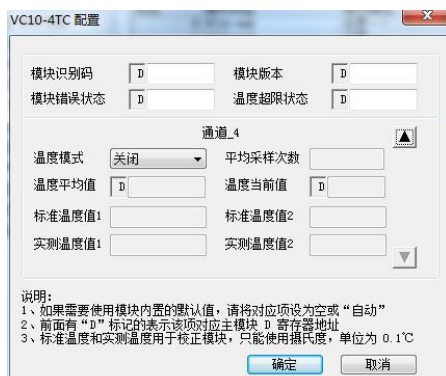

图 4-5 模块第 1 通道设置更改界面



图 4-6 模块第 2 通道设置更改界面

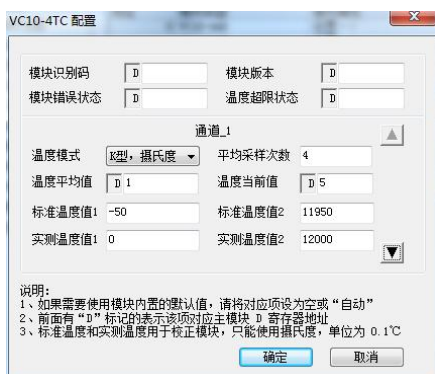

图 4-7 模块第 3 通道设置更改界面

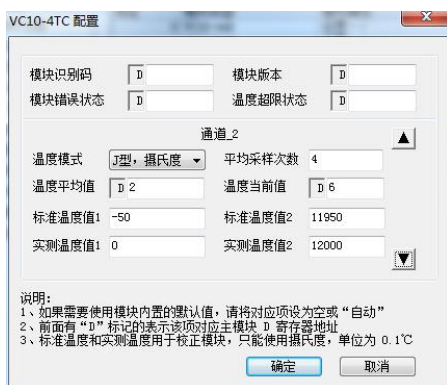

图 4-8 模块第 4 通道设置更改界面

5 运行检查

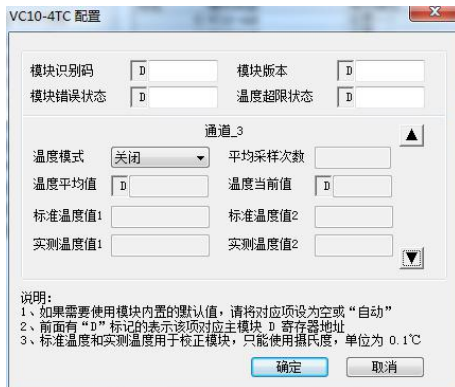
5.1 例行检查

1. 检查模拟输入布线是否满足要求，参考 1.3 布线说明。
2. 检查 VC10-4TC 扩展电缆是否可靠插入扩展电缆接口。
3. 检查 5V 及 24V 电源是否过载。注意：VC10-4TC 数字部分的电源来自主模块，通过扩展电缆供应。
4. 检查应用程序，确保应用中选择的是正确的操作方法及参数范围。
5. 置 VC10 主模块为 RUN 状态。

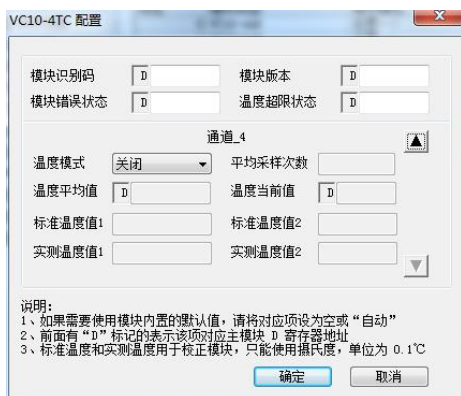
5.2 故障检查

如果 VC10-4TC 运行不正常，请检查下列项目。

● 检查“POWER”指示灯状态

点亮：扩展电缆连接正确；

熄灭：检查扩展电缆连接情况及主模块情况。

● 检查模拟布线。

● 检查“24V”指示灯状态

点亮：24Vdc 电源正常；

熄灭：24Vdc 电源可能有故障，若 24Vdc 电源正常，则是 VC10-4TC 故障。

● 检查“RUN”指示灯状态

高速闪烁：VC10-4TC 运行正常；

慢速闪烁或熄灭：检查后台软件中 VC10-4TC 配置界面中**错误状态**一栏中的信息。

用户须知

1. 保修范围指可编程控制器本体。
2. **保修期为十八个月**，保修期内正常使用情况下，产品发生故障或损坏，我公司免费维修。
3. **保修期起始时间为产品制造出厂日期**，机器编码是判断保修期的唯一依据，无机器编码的设备按过保处理。
4. 即使在保修期内，如发生以下情况，将收取一定的维修费用：
 - 不按用户手册操作导致的机器故障；
 - 由于火灾、水灾、电压异常等造成的机器损坏；
 - 将可编程控制器用于非正常功能时造成的损坏。
5. 服务费按实际费用计算，如另有合同，以合同优先的原则处理。
6. 请您务必保留此卡，并在保修时出示给维修单位。
7. 如您有问题可与代理商联系，也可直接与我公司联系。

VC10-4TC Thermocouple Temperature Input Module User Manual

Note:

To reduce the chance of accident, please carefully read the operating instructions and safety precautions prior to use. Only adequately trained personnel shall install or operate this product. In operation, strict compliance with applicable safety rules in the industry, the operating instructions and safety precautions in this book is required.

1 Port Description

1.1 Port

The extension port and user port of VC10-4TC are both protected by a cover, as shown in Figure 1-1. Removing the covers reveals the extension port and user port, as shown in Figure 1-2.

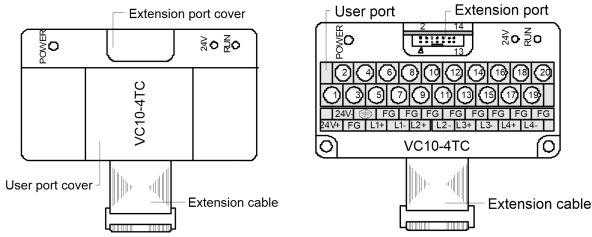

Figure 1-1 VC10-4TC appearance Figure 1-2 VC10-4TC ports

The extension cable connects VC10-4TC to the system, while the extension port connects VC10-4TC to another extension module of the system. For details on connection, see 1.2 Connecting Into System.

The user port of VC10-4TC is described in Table 1-1.

Table 1-1 User port description

Terminal	Name	Description
1	24V+	Analog power supply 24V+
2	24V-	Analog power supply 24V-
3	•	NC
4	⊕	GND
5, 9, 13, 17	L1+, L2+, L3+, L4+	Positive poles of thermocouples for channels 1 to 4
7, 11, 15, 19	L1-, L2-, L3-, L4-	Negative poles of thermocouples for channels 1 to 4
6, 8, 10, 12, 14, 16, 18, 20	FG	Shielding GND

1.2 Connecting Into System

Through the extension cable, you can connect VC10-4TC to VC10 series basic module or other extension modules. While through the extension port, you can connect other VC10 series extension modules to VC10-4TC. See Figure 1-3.

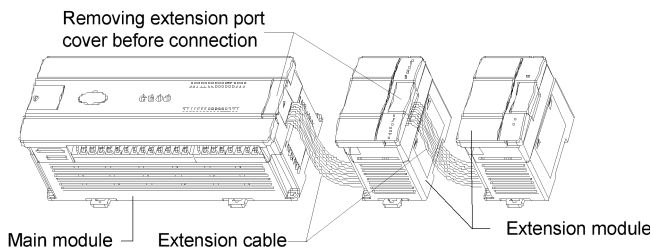

Figure 1-3 Connecting into system

1.3 Wiring

The wiring of user port is shown in Figure 1-4.

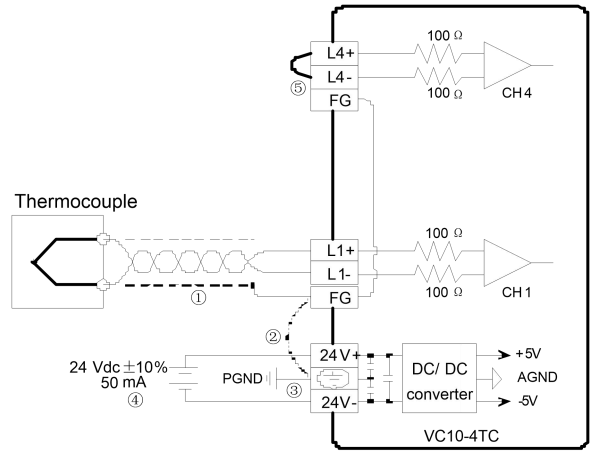

Figure 1-4 Wiring of VC10-4TC user port

The circled 1 ~ 6 stands for the six points to be observed during wiring:

1. Thermocouple signals are connected through screen compensation cables, which should be routed separate from power cables or other EMI-generating cables. Long compensation cables are susceptible to EMI, so the compensation cables should be advisably shorter than 100m. Compensation cable has impedance, which can cause measurement error. This problem can be addressed through characteristics adjustment. For details, see 3 Setting Characteristics.
2. If strong EMI exists, connect the FG and PG terminals together.
3. Properly ground the module's PG terminal.
4. The basic module's 24Vdc auxiliary power or any qualified external power supply can be used to feed the module's analog circuit.
5. Short the positive and negative terminals of unused channels to avoid detecting error data from that channel.

2 Indices

2.1 Power Supply

Table 2-1 Power supply

Item	Description
Analoge circuit	24Vdc (-15%~20%), maximum allowable ripple voltage: 5%, 50mA (from the basic module or external power supply)
Digital circuit	5Vdc, 72mA (from basic module)

2.2 Performance

Table 2-2 Performance

Item	Index			
	Celsius(°C)		Fahrenheit (°F)	
Input signal	Thermocouple: type K, J, E, N, T, R or S (all accessible to each channel), 4 channels			
Conversion speed	(240ms±2%)ms × 4 channels (no conversion for unused channels)			
Rated temperature range	Type K	-100°C~1200°C	Type K	-148°F ~ +2192°F
	Type J	-100°C~1000°C	Type J	-148°F ~ +1832°F
	Type E	-100°C~1000°C	Type E	-148°F ~ +1832°F
	Type N	-100°C~1200°C	Type N	-148°F ~ +2192°F
	Type T	-200°C ~ +400°C	Type T	-328°F ~ +752°F
	Type R	0°C ~ 1600°C	Type R	32°F ~ 2912°F
	Type S	0°C ~ 1600°C	Type S	32°F ~ 2912°F
Digital output	12-digit AD conversion, 16-digit complement for storage			
	Type K	-1000 ~ +12000	Type K	-1480 ~ +21920
	Type J	-1000 ~ +10000	Type J	-1480 ~ +18320
	Type E	-1000 ~ +10000	Type E	-1480 ~ +18320
	Type N	-1000 ~ +12000	Type N	-1480 ~ +21920
	Type T	-2000 ~ +4000	Type T	-3280 ~ +7520
	Type R	0 ~ 16000	Type R	320 ~ 29120
Type S	0 ~ 16000	Type S	320 ~ 29120	

Item	Index			
	Celsius(°C)		Fahrenheit (°F)	
Lowest resolution	Type K	0.3°C	Type K	0.54°F
	Type J	0.2°C	Type J	0.36°F
	Type E	0.3°C	Type E	0.54°F
	Type N	0.3°C	Type N	0.54°F
	Type T	0.2°C	Type T	0.36°F
Lowest resolution	Type R	0.5°C	Type R	0.9°F
	Type S	0.5°C	Type S	0.9°F
Accuracy	± (0.5% full range+1°C), water freezing point: 0°C/32°F			
Isolation	Between analog circuit and digital circuit: photocoupler. Between analog circuit and input 24Vdc power: internal isolation. Between analog channels: none			

2.3 Buffer Memory

VC10-4TC exchanges data with the basic module through Buffer Memory (BFM). After VC10-4TC is set through the host software, the basic module will write data into VC10-4TC BFM to set the state of VC10-4TC, and display the data from VC10-4TC on the host software interface. See figures 4-1 ~ 4-8. Table 2-3 describes the contents of the BFM of VC10-4TC.

Table 2-3 BFM contents

BFM	Content	Default	Property
#100 ~ #103	Average temperature of CH1~CH4		R
#200 ~ #203	Current temperature of CH1~CH4		R
#300	Error status word 0		R
#301	Error status word 1		R
#600	Channel mode word	0x0000	RW
#700 ~ #703	Sampling times respectively for averages of CH1 ~ CH3	8	RW
#900	CH1-D0	0 (input mode 0)	RW
#901	CH1-A0	0 (input mode 0)	RW
#902	CH1-D1	12000 (input mode 0)	RW
#903	CH1-A1	12000 (input mode 0)	RW
#904	CH2-D0	0 (input mode 0)	RW
#905	CH2-A0	0 (input mode 0)	RW
#906	CH2-D1	12000 (input mode 0)	RW
#907	CH2-A1	12000 (input mode 0)	RW
#908	CH3-D0	0 (input mode 0)	RW
#909	CH3-A0	0 (input mode 0)	RW
#910	CH3-D1	12000 (input mode 0)	RW
#911	CH3-A1	12000 (input mode 0)	RW
#912	CH4-D0	0 (input mode 0)	RW
#913	CH4-A0	0 (input mode 0)	RW
#914	CH4-D1	12000 (input mode 0)	RW
#915	CH4-A1	12000 (input mode 0)	RW
#3000	Cold end temperature	For test	R
#4094	Module software version	0x1000	R
#4095	Module ID	0x4041	R

Note:

- CH1 stands for channel 1; CH2, channel 2; CH3, channel 3, and so on.
- Property explanation: R means read only. An R element cannot be written. RW means read and write. Reading from a non-existent element will get 0.
- BFM#200 ~ BFM#203: current temperature. Unit: 0.1°C/°F (depending on the value of BFM#600). The average value are stored in BFM#100-BFM#103.
- BFM#300 error status information is shown in Table 2-4.

Table 2-4 BFM#300 status information

Bit status of BFM#300	ON (1)	OFF (0)
b0: error	b1 or b2 is ON, AD conversion of all channels stopped	No error
b2: power failure	24Vdc power supply failed	Power supply normal
b3: hardware fault	AD converter or other hardware faulty	Hardware normal
b10: digital range error	Digital output after AD conversion outside the range of -2048 ~ 2047	Digital output normal

Bit status of BFM#300	ON (1)	OFF (0)
b12 ~ b15: reserved		

5. BFM#301 error status information is shown in Table 2-5.

Table 2-5 BFM#301 status information

Channel	Bit	ON (1)	OFF (0)
1	b0	CH1 temperature lower than lower limit	CH1 normal
	b1	CH1 temperature higher than upper limit	CH1 normal
2	b2	CH2 temperature lower than lower limit	CH2 normal
	b3	CH2 temperature higher than upper limit	CH2 normal
3	b4	CH3 temperature lower than lower limit	CH3 normal
	b5	CH3 temperature higher than upper limit	CH3 normal
4	b6	CH4 temperature lower than lower limit	CH4 normal
	b7	CH4 temperature higher than upper limit	CH4 normal
Reserved	b8 ~ b15		

6. BFM#600: channel mode selection, used to set the working modes of CH1 ~ CH4. See Figure 2-1 for their correspondence.

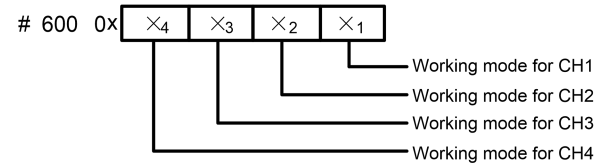

Figure 2-1 Mode setting element vs. channel

The exact meaning of the X in the channel mode is shown in Table 2-6. The conversion time of every channel is 240ms. When a channel is set closed, it will not perform AD conversion, thereby reducing the total conversion time.

Table 2-6 Meaning of X in channel mode

No.	X (hexadecimal)	Meaning
1	0	K type thermocouple. Digital signal unit: 0.1°C
2	1	K type thermocouple. Digital signal unit: 0.1°F
3	2	J type thermocouple. Digital signal unit: 0.1°C
4	3	J type thermocouple. Digital signal unit: 0.1°F
5	4	E type thermocouple. Digital signal unit: 0.1°C
6	5	E type thermocouple. Digital signal unit: 0.1°F
7	6	N type thermocouple. Digital signal unit: 0.1°C
8	7	N type thermocouple. Digital signal unit: 0.1°F
9	8	T type thermocouple. Digital signal unit: 0.1°C
10	9	T type thermocouple. Digital signal unit: 0.1°F
11	A	R type thermocouple. Digital signal unit: 0.1°C
12	B	R type thermocouple. Digital signal unit: 0.1°F
13	C	S type thermocouple. Digital signal unit: 0.1°C
14	D	S type thermocouple. Digital signal unit: 0.1°F
15	E	Channel closed
16	F	Channel closed

7. BFM#700 ~ BFM#703: average sampling times setting. Range: 1 ~ 256. If the setting is outside this range, the value will be reset to the default 8.

5. BFM#900 ~ BFM#915: channel characteristics setting data register. Use two points to define the channel characteristic. D0 and D1 are the channel digital output, in the unit of 0.1°C. A0 and A1 are the actual temperature input of the channel, also in the unit of 0.1°C. Each channel occupies 4 words.

You can change the channel characteristic by changing D0 and D1. The setting range of D0 is -1000~1000 (0.1°C); D1, 11,000~13,000 (0.1°C). If the setting is outside this range, VC10-4TC will not accept it, but maintain the original valid setting. Note that the characters are all in 0.1°C unit.

Convert Fahrenheit parameters as per the following formula before using them in the characteristic setting: Celsius = 5/9 × (Fahrenheit - 32)

9. BFM#4094: software version information, displayed automatically as **Module Version** in **VC10-4TC Configuration** dialogue box of the host software, as shown in Figure 4-1.

10. BFM#4095: module ID. The ID of VC10-4TC is 0x4041. The PLC user program can use this code to identify the module before transceiving data.

3 Characteristic Setting

The input channel characteristic of VC10-4TC is the linear relationship between the channel's analog input A and digital output D. It can be set by the user. Each channel can be considered as the model shown in Figure 3-1. As it is of linear characteristic, the channel characteristic can be defined by

just two points: P0 (A0, D0) and P1 (A1, D1), where D0 is the channel's digital output corresponding to analog input A0, and D1 is the channel's digital output corresponding to analog input A1.

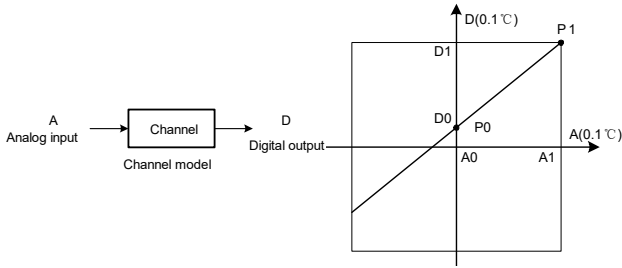
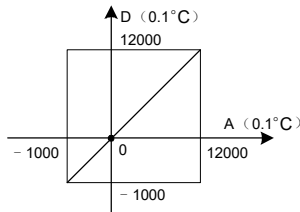

Figure 3-1 VC10-4TC channel characteristic setting

The channel characteristic setting is used to correct the onsite linear error in VC10-4TC measurement caused by the different ambient temperatures and compensation cables.

To simplify the operation process without affecting functions, A0 and A1 are respectively fixed to 0 and 12,000 (unit: 0.1°C) in the present mode. That is to say, the A0 and A1 in Figure 3-1 are respectively 0 and 12,000 (unit: 0.1°C). Users cannot change their values.

If you just set the channel mode without changing D0 and D1, the channel characteristic vs. 0 mode should be as shown in Figure 3-2.



Default (not adjusted)

Figure 3-2 Characteristic vs. 0 mode without changing D0 and D1

Note that when the mode is set to 1 or 3, the output will be in 0.1°F unit, and the temperature data read from the output data zone will be in 0.1°F unit. But the data in the channel characteristic setting zone will still be in 0.1°C unit, which means the data in the channel characteristic setting zone is always in 0.1°C unit. Keep this in mind when changing D0 and D1.

You can change the characteristics by changing D0 and D1. The setting range of D0 is -1000~1000 (0.1°C); D1, 11000~13000 (0.1°C). If the setting is outside this range, VC10-4TC will not accept it, but maintain the original valid setting. Figure 3-3 provides you an example of changing K type and J type thermocouple characteristic when the VC10-4TC measured value is 5°C (41°F) higher the actual value.

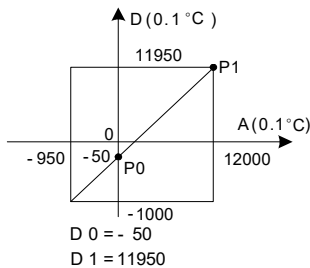

Figure 3-3 Changing characteristic

4 Application Example

4.1 Basic Application

Example: Connect channels 1 and 2 of VC10-4TC respectively to K and J type thermocouples with Celsius output, connect channel 3 to K type thermocouples with Fahrenheit output, and close CH4. Set the average sampling times of CH1 ~ CH3 to 4, and use data registers D1 ~ D3 to receive the average value.

The setting interface of output CH1 is shown in Figure 4-1. After the setting, click the downward arrow button → to continue to set CH 2 ~ CH4, whose setting interfaces are shown in figures 4-2 ~ 4-4. For detailed software usage, see *VC10 Series PLC Programming Manual*.

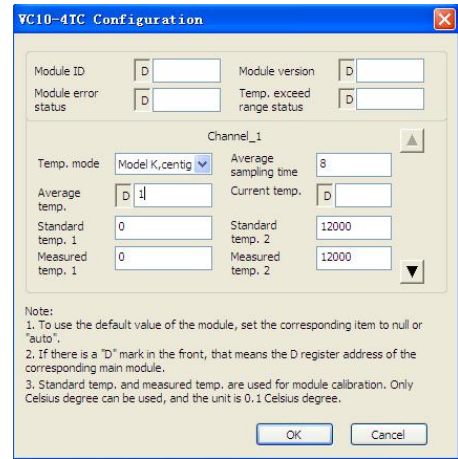

Figure 4-1 CH1 setting interface

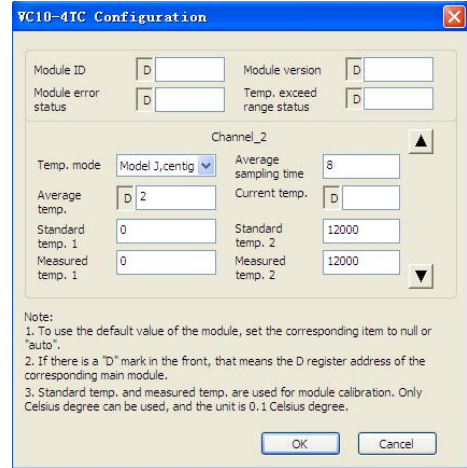

Figure 4-2 CH2 setting interface

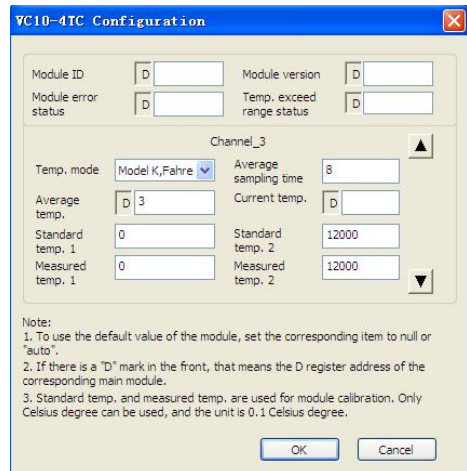

Figure 4-3 CH3 setting interface

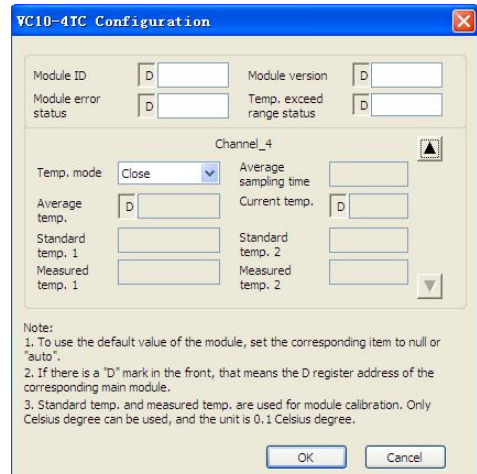

Figure 4-4 CH4 setting interface

4.2 Changing Characteristics

Example: Connect CH1 of VC10-4TC to K thermocouple with Celsius output, connect CH2 to J type thermocouple Fahrenheit output. Close CH3 and CH4. Set characteristics of channels 1 and 2 as per Figure 3-3. Set the average sampling times to 4 and use registers D1 and D2 to receive the average value.

VC10-4TC Configuration

Module ID: D Module version: D
Module error status: D Temp. exceed range status: D

Channel_1

Temp. mode: Model K, centig Average sampling time: 8
Average temp.: D 1 Current temp.: D
Standard temp. 1: -50 Standard temp. 2: 11950
Measured temp. 1: 0 Measured temp. 2: 12000

Note:
1. To use the default value of the module, set the corresponding item to null or "auto".
2. If there is a "D" mark in the front, that means the D register address of the corresponding main module.
3. Standard temp. and measured temp. are used for module calibration. Only Celsius degree can be used, and the unit is 0.1 Celsius degree.

OK Cancel

Figure 4-5 Changing CH1 characteristic

VC10-4TC Configuration

Module ID: D Module version: D
Module error status: D Temp. exceed range status: D

Channel_2

Temp. mode: Model J, centig Average sampling time: 8
Average temp.: D 2 Current temp.: D
Standard temp. 1: 0 Standard temp. 2: 12000
Measured temp. 1: 0 Measured temp. 2: 12000

Note:
1. To use the default value of the module, set the corresponding item to null or "auto".
2. If there is a "D" mark in the front, that means the D register address of the corresponding main module.
3. Standard temp. and measured temp. are used for module calibration. Only Celsius degree can be used, and the unit is 0.1 Celsius degree.

OK Cancel

Figure 4-6 Changing CH2 characteristic

VC10-4TC Configuration

Module ID: D Module version: D
Module error status: D Temp. exceed range status: D

Channel_3

Temp. mode: Close Average sampling time: 8
Average temp.: D 3 Current temp.: D
Standard temp. 1: 0 Standard temp. 2: 12000
Measured temp. 1: 0 Measured temp. 2: 12000

Note:
1. To use the default value of the module, set the corresponding item to null or "auto".
2. If there is a "D" mark in the front, that means the D register address of the corresponding main module.
3. Standard temp. and measured temp. are used for module calibration. Only Celsius degree can be used, and the unit is 0.1 Celsius degree.

OK Cancel

Figure 4-7 Changing CH3 characteristic

5 Operation Inspection

5.1 Routine Inspection

1. Check that the wiring of analog input meets the requirements (see 1.3 *Wiring*).
2. Check that the extension cable of VC10-4TC is properly inserted in the extension port.
3. Check that the 5V and 24V power supplies are not overloaded. Note: The digital circuit is powered by the basic module through extension cable.
4. Check the application, make sure the operation method and parameter range are correct.

5. Set the VC10 basic module to RUN state.

5.2 Inspection Upon Fault

In case of abnormality, check the following items:

- The status of the POWER indicator

ON: the extension cable is properly connected;

OFF: check the extension cable connection and the basic module.

- The wiring of analog input

- The status of the 24V indicator

ON: 24Vdc power supply normal;

OFF: 24Vdc power supply possibly faulty, or VC10-4TC faulty.

- The status of the RUN indicator

Flash quickly: VC10-4TC in normal operation;

Flash slowly or OFF: Check the **Error Status** in **VC10-4TC Configuration** dialogue box through the host software.

Notice

1. The warranty range is confined to the PLC only.
2. **Warranty period is 18 months**, within which period conducts free maintenance and repairing to the PLC that has any fault or damage under the normal operation conditions.
3. **The start time of warranty period is the delivery date of the product**, of which the product SN is the sole basis of judgment. PLC without a product SN shall be regarded as out of warranty.
4. Even within 18 months, maintenance will also be charged in the following situations:
 - Damages incurred to the PLC due to mis-operations, which are not in compliance with the User Manual;
 - Damages incurred to the PLC due to fire, flood, abnormal voltage, etc;
 - Damages incurred to the PLC due to the improper use of PLC functions.
5. The service fee will be charged according to the actual costs. If there is any contract, the contract prevails.
6. Please keep this paper and show this paper to the maintenance unit when the product needs to be repaired.
7. If you have any question, please contact the distributor or our company directly.

All rights reserved. The contents in this document are subject to change without notice.